

Lattis Matrix Switcher Example 3: Infrared and RS-232 Control

Source Components

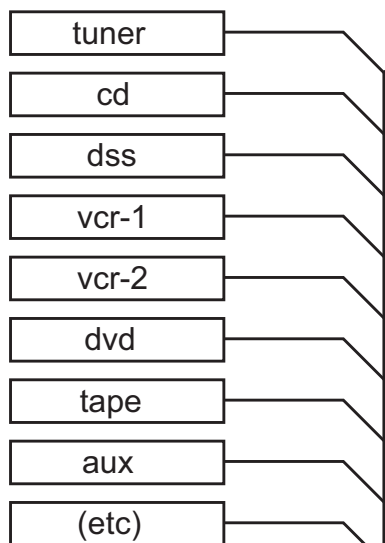

Zone Amplifiers and Speakers

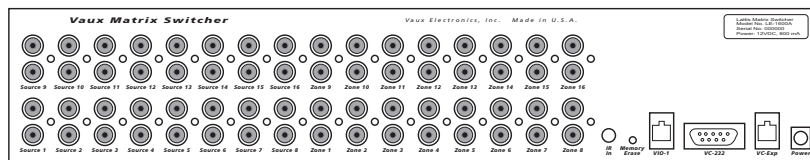
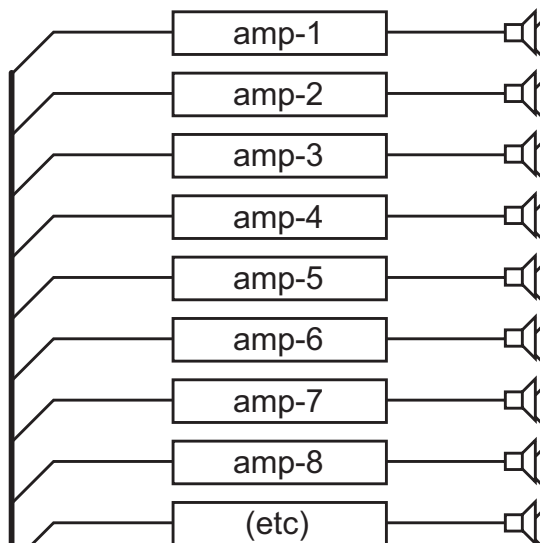

Lattis Matrix Switcher

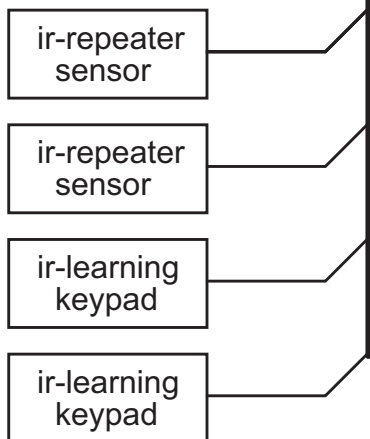
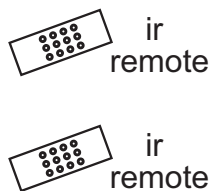
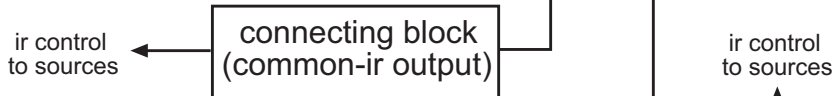

Infrared Control

Control some zones using Vaux RC-16-IR remote controls, or ir-learning remote controls or keypads. Connect repeater/keypad output to Lattis Ir-In jack (or place emitter on front panel). Since Vaux zone number is embedded in commands, only one ir-input is needed.

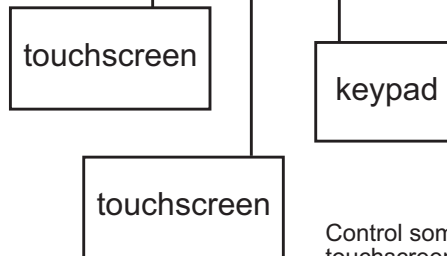
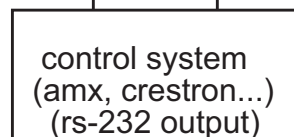

RS-232 Control

Control some zones using touchscreens and/or keypads on control system connected via rs-232.